

ADVANCES IN COMPUTATIONAL MODELING OF COCHLEAR IMPLANT PHYSIOLOGY AND PERCEPTION

I. C. Bruce^{1,2} M. W. White³, L. S. Irlicht^{2,4}, S. J. O'Leary² and G. M. Clark²

¹*Department of Biomedical Engineering, Johns Hopkins University
505 Traylor Building, 720 Rutland Ave, Baltimore MD 21205, USA*

²*Department of Otolaryngology, The University of Melbourne
384-388 Albert Street, East Melbourne VIC 3002, Australia*

³*Department of Electrical and Computer Engineering
North Carolina State University, Raleigh NC 27695, USA*

⁴*Rothschild Australia Asset Management, Level 10,
One Collins Street, Melbourne VIC 3000, Australia*

1. Introduction

Models of cochlear implant physiology and perception have historically utilized deterministic descriptions of auditory-nerve (AN) responses to electrical stimulation, which ignore stochastic activity present in the response. Physiological models of AN responses have been developed that do incorporate stochastic activity [8][13][14][27][38][39], but the consequences of stochastic activity for the perception of cochlear implant stimulation have not been investigated until recently [3].

Such an investigation is prompted by inaccuracies in predicting cochlear implant perception by deterministic models. For example, studies of single-fiber responses, where only an arbitrary deterministic measure of threshold is recorded, do not accurately predict perceptual threshold versus phase duration (strength-duration) curves for sinusoidal stimulation [24] or for pulsatile stimulation [25][26]. Furthermore, strength-duration curves of cochlear implant users are not well predicted by deterministic Hodgkin–Huxley type models [25] [30].

However, the complexity of previous stochastic physiological models has made the computation of responses for large numbers of fibers both laborious and time-consuming. Furthermore, the parameters of these models are often not easily matched to the fiber characteristics of the auditory nerve in humans or other mammals. This has prompted us to develop a simpler and more computationally efficient model of electrical stimulation of the auditory nerve [1][2][4] which is capable of direct and rapid prediction of perceptual data [3].

2. Computational Modeling of Cochlear Implant Physiology

In [1] and [4] we have described a model of the AN response to electrical stimulation, following the conceptual approach used in [35], [38] and [39]. This model can be represented by the electrical circuit diagram shown in Figure 1. Based on the Hill threshold model [12], our model includes a number of significant components of action potential generation, including membrane noise, as recorded by Verveen and colleagues [35], which has a Gaussian amplitude distribution and a $1/f$ frequency spectrum. Threshold models are much simpler conceptually and are more computationally efficient than Hodgkin–Huxley models. They

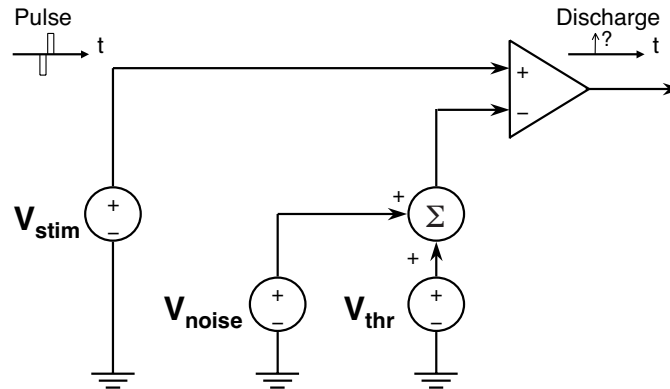

Figure 1 Stochastic model of single-pulse response. Reprinted from Fig. 2 of [4] © 1999 IEEE.

have also been shown to provide a good approximation to more complex models [16]. Additionally, our model can be fitted easily to the statistics of AN parameters collected from anatomical and physiological studies.

We are able to derive an analytical description of this model, because it is in effect a Bernoulli process, where a discharge in response to a pulse is considered to have a value of 1 and no discharge has a value of 0. The probability of discharge, $p(n)$, in response to a single pulse approximated by the equation [1] [4]

$$p(n) = \frac{1}{2} \left(1 + \operatorname{erf} \left(\frac{V_{\text{stim}}(n) - V_{\text{thr}}(n)}{\sqrt{2}\sigma} \right) \right) \quad (1)$$

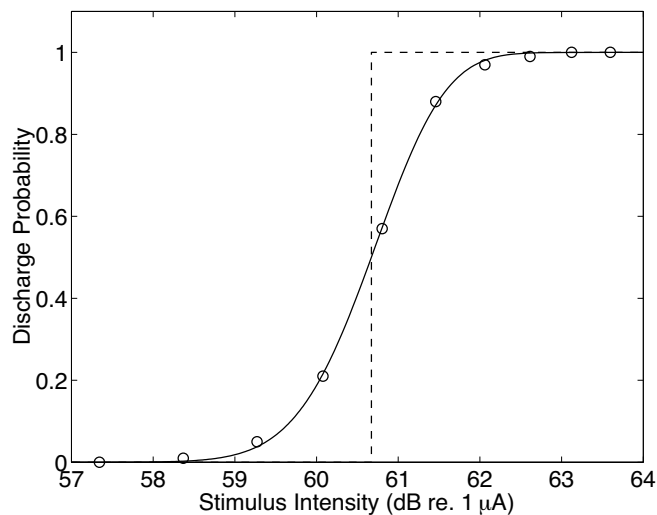

Figure 2 Stochastic (solid line) and deterministic (dashed line) model fits to discharge probability data (circles) from Neuron 2-22 of [15].

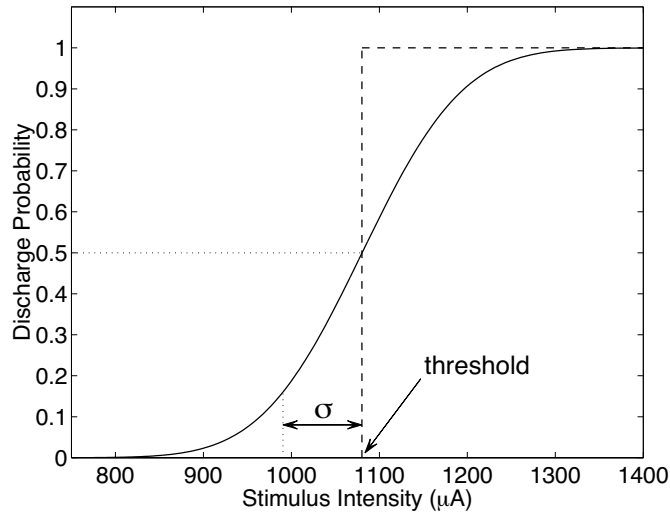

Figure 3 Stochastic (solid line) and deterministic (dashed line) model I/O functions showing how threshold and the standard deviation of the Gaussian noise, σ , are defined to determine RS ($= \sigma/\text{threshold}$).

where σ is the standard deviation of the noise potential, $V_{\text{noise}}(n)$. The equivalent deterministic model can be simulated by setting the noise to zero ($\sigma = 0$), producing a step function at $V_{\text{thr}}(n)$ [1][4].

Deterministic and stochastic model fits to physiological data from a single cat AN fiber are plotted in Figure 2. The stochastic model provides a much better fit to the data ($r^2 = 1.0$) than does the deterministic model ($r^2 = 0.92$).

Following Verveen et al.'s convention, we characterize the input/output (I/O) functions by defining threshold as the intensity corresponding to a discharge probability of 0.5 and

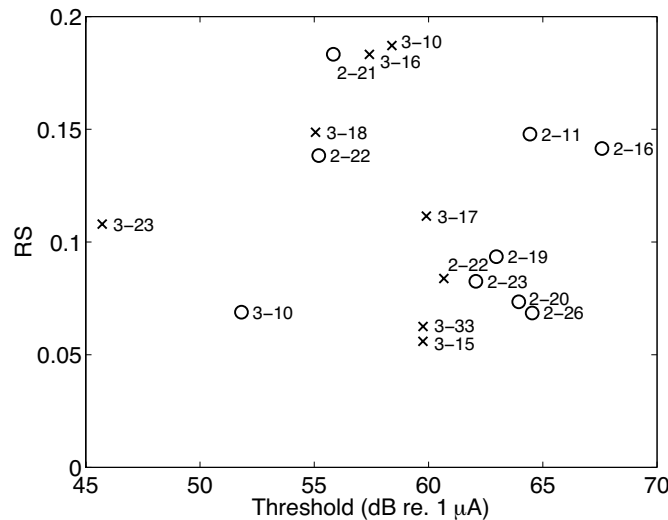

Figure 4 Relative spread versus threshold for neurons from [15] as labeled, in response to a single biphasic pulse of duration 200 $\mu\text{s}/\text{phase}$ (x) or 400 $\mu\text{s}/\text{phase}$ (o). Reprinted from Fig. 5 of [4] © 1999 IEEE.

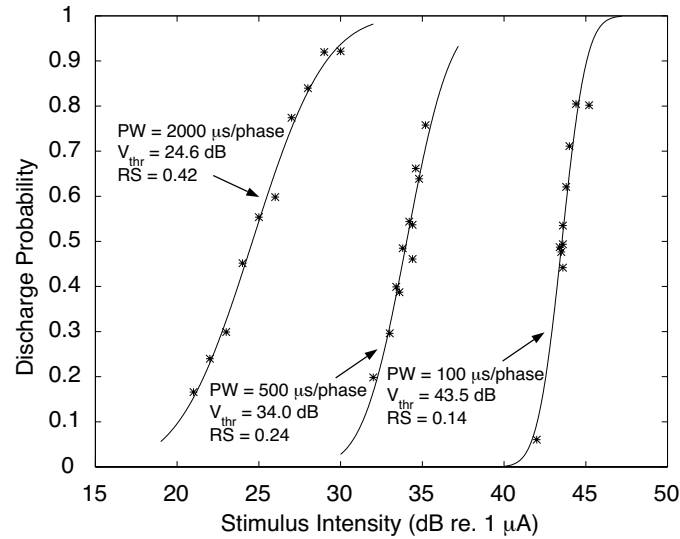

Figure 5 Discharge probability vs. stimulus intensity for single symmetric biphasic anodic/cathodic pulses of durations 100, 500 and 2,000 $\mu\text{s}/\text{phase}$, from Cat 76: Unit 2 in the Dynes data set [8]. Plotted are individual measures (asterisks) and stochastic model fits (solid lines). Reprinted from Fig. 6 of [4] © 1999 IEEE.

Relative Spread (RS) as the standard deviation of the Gaussian noise divided by threshold. The deterministic model is characterized by threshold alone ($\sigma=0$), as illustrated in Figure 3.

In order to model the response of a population of AN fibers we need to determine the model parameters for each neuron in the population, as well as the intensity of the excitatory current at the initial site of action potential generation in each neuron.

Figure 4 shows a plot of RS versus threshold for 15 neurons from the Javel et al. data set for a 200- $\mu\text{s}/\text{phase}$ (x) or a 400- $\mu\text{s}/\text{phase}$ (o) biphasic pulse. It can be seen that both thresholds and RSs cover a broad range of values. Combining these data with similar published data [19][34], we are able to estimate the distribution of I/O function parameters (threshold and RS) for a local population of fibers in the AN. In our “total AN” (large-scale population) model we simulate this distribution of I/O functions [4].

Although higher rate pulsatile stimuli are typically used in modern cochlear implants, necessitating short phase durations (i.e., pulse widths), there is a relatively large body of psychophysical data available in which long phase duration stimuli were used. Furthermore, these psychophysical data show large discrepancies with deterministic model predictions at long phase durations [24][25][26][30]. However, the method used for suppressing the stimulus artifact in the Javel et al. experiments did not allow for much data collection at phase durations longer than 400 $\mu\text{s}/\text{phase}$ and none longer 600 $\mu\text{s}/\text{phase}$. Thus we also conducted a *post hoc* analysis of previously unpublished data collected by Dynes from single AN fibers of cats [8], where a pair of closely spaced micropipettes were used in differential-like recording to produce a high signal-to-artifact ratio even at long phase durations.

In Figure 5 discharge probability is plotted versus stimulus intensity curves for three different phase durations from Cat 76: Unit 2 in the Dynes data set. As the phase duration increases, the slope of the curve becomes shallower, indicating a greater dynamic range. Computing the RSs of these curves shows that RS increases as the phase duration of the

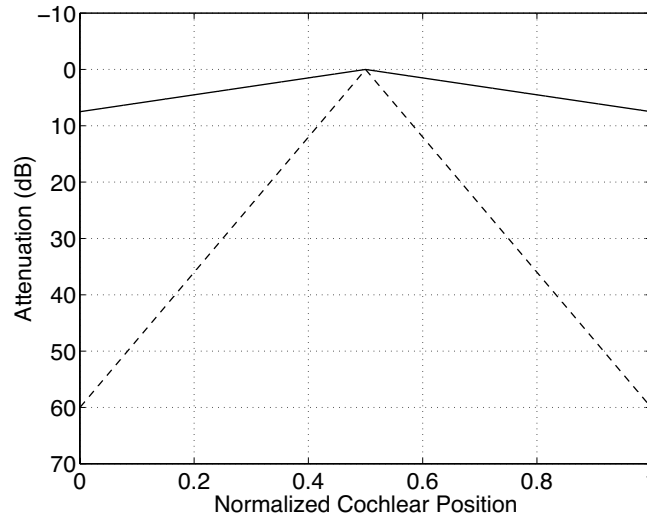

Figure 6 Attenuation of the stimulus across the cochlea for monopolar (solid line) and bipolar (dashed line) electrode configurations. Reprinted from Fig. 9 of [4] © 1999 IEEE.

anodic/cathodic biphasic stimulus increases. This effect is seen in all fibers of this data set. For every fiber, the RS increases as the duration per phase of the stimulus increases. To incorporate this behavior in our model, we fit discharge-probability functions (Eq. 1) to the complete data set and calculated the mean threshold and RS at phase durations of 100, 500, 2000 and 5000 $\mu\text{s}/\text{phase}$. We then fit appropriate functions to threshold and RS versus phase duration plots. These functions are used in the model to interpolate values of threshold and RS at phase durations other than those used in the Dynes experiments [8].

The two electrode configurations that we investigate in these studies are commonly known as monopolar and bipolar. In the case of monopolar stimulation, the active electrode is one of the electrodes on the array within the cochlea and the return electrode is an electrode external to the cochlea. In the case of bipolar stimulation both the active electrode and the return electrode are on the electrode array within the cochlea.

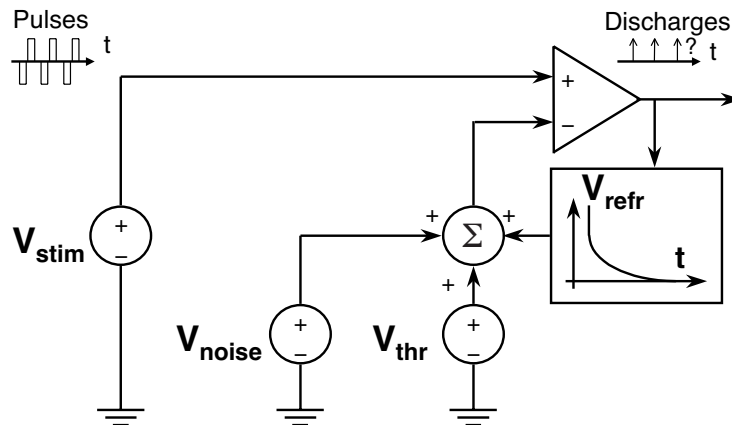

Figure 7 Stochastic model of pulse-train response.

Following [21], we approximate the electrode array by a point source of current at the active electrode and the AN tissue by a homogeneous resistive medium consisting of a uniform density of single AN fibers. To calculate the stimulus intensity at each AN fiber, we assume that the stimulus is attenuated at the rate of 0.5 dB/mm for monopolar stimulation [18] and 4 dB/mm for bipolar stimulation—the latter value is appropriate for both radial-bipolar pairs [18] and closely spaced longitudinal-bipolar pairs [20]. Modeling an electrode placed 15 mm inside a cochlea 30-mm long produces attenuation curves as shown in Figure 6.

In [1] and [2] we go on to extend this model to describe responses to pulse-train stimuli, by introducing a phenomenological refractory mechanism. To the single-pulse model of [1] and [4] we add a refractory potential as shown in Figure 7. Following an action potential, the threshold with which the stimulus potential is compared is raised over the refractory period by some chosen function, typically an exponential [1][2][8][22]. We also derive analytical expressions to approximate the pulse-train model, which although more complex than the single-pulse model, are still computationally efficient and can be fitted easily to the statistics of AN parameters collected from physiological studies.

3. Computational Modeling of Cochlear Implant Perception

In [3] we investigate whether inaccuracies in predictions of loudness perception could be due to ignoring the stochastic response of the AN to electrical stimulation. In order to avoid the complication of inter-pulse interactions and to enable the use of the simpler and computationally faster single-pulse model as shown in Figure 1, we restrict our investigation to single biphasic pulses and low-rate (< 200 pulses per second) pulse trains. We derive a model of loudness based on the single-pulse model of neural excitation developed in [1] and [4] and compare the deterministic and stochastic model predictions. We develop the psychophysical (perceptual) section of the model in such a way that signal detection theory can be applied to predict directly how behavioral threshold, dynamic range and intensity difference limen change with stimulus parameters and nerve survival. The resulting model is shown in Figure 8.

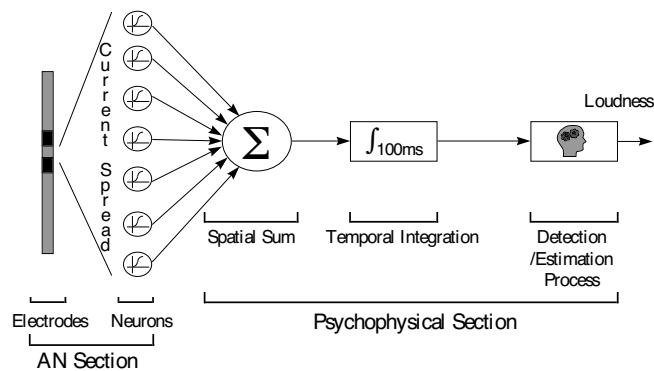

Figure 8 Composite computational physiological and perceptual model. Reprinted from Fig. 1 of [3] © 1999 IEEE.

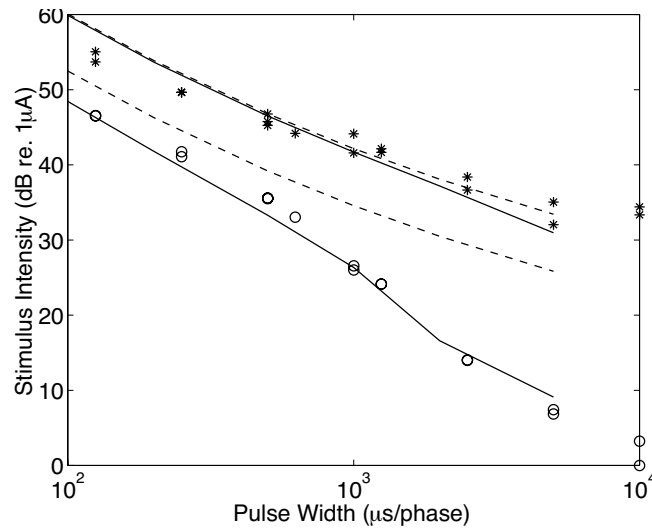

Figure 9 Perceptual data for uncomfortable loudness (*) and threshold (o) are plotted against phase duration, along with the deterministic (dashed lines) and stochastic (solid lines) model predictions.

In all the cases examined in this set of studies, the stochastic model predicts perceptual data better than does the deterministic model. For example, plotted in Figure 9 are perceptual data from a cochlear implant user showing uncomfortable loudness and threshold versus phase duration. While the stochastic and deterministic models predict similar uncomfortable loudness levels, the deterministic model overestimates the threshold data, particularly for longer pulse durations. In contrast, the stochastic model, consistent with the physiological data, predicts (i) absolute values of threshold that are significantly lower than those predicted by the deterministic model, and (ii) slopes that begin to steepen with phase durations greater than 500 $\mu\text{s}/\text{phase}$ and slopes that are steeper than -6 dB/doubling in the region from 1000 to 2000 $\mu\text{s}/\text{phase}$. This is more than would be expected if it were assumed that threshold corresponds to a certain level of charge delivered by an implant.

Our study [3] also shows that the stochastic model better predicts perceptual data for:

- *threshold* versus *phase duration* as a function of *electrode configuration* (bipolar or monopolar),
- the ratio of *bipolar dynamic range* versus *monopolar dynamic range*,
- *threshold* versus *number of pulses* (temporal-integration), and
- *intensity difference limen* as a function of intensity (Weber functions).

The physiological model is based on data from the cat AN, but the resulting perceptual model gives good qualitative predictions of data from implanted humans, monkeys, guinea pigs and cats. This suggests that stochastic activity in the AN is perceptually significant across a wide range of measures of loudness perception and regardless of the species, although anatomical, physiological and cognitive differences may have small quantitative effects.

Ferguson et al. [9] have implemented a model similar to ours and have compared its predictions of threshold as a function of pulse duration for monopolar and bipolar stimulation modes with experimental data. Analysis of data from three species indicated that the variance of perceptual thresholds is also a function of phase duration, and that these results are

corroborated by the predictions of the stochastic version of the model. These results are not predicted by the deterministic model, indicating that the importance of stochastic activity in the AN extends beyond the perceptual data investigated in our own studies.

4. Future Directions

In these studies we derive a model of loudness in cochlear implants users based on physiological data and use this model to investigate a number of different perceptual phenomena. In all the cases examined so far, the model predicts the perceptual performance of cochlear implant users significantly better when stochastic activity is included in the neural section of the model.

However, extensions or revisions of this AN model may further improve predictions and our understanding of the functional significance of the physiology—specific suggestions follow.

The neural section of our model is derived from physiological data collected in cats. Further physiological data may be collected from humans using cochlear implant telemetry and non-invasive electrophysiology, which should prove useful in refining our simple model of current spread and neural response. A model of current spread in the human cochlea constructed from human cochlear sections [6] may also help to this end.

Another extension to the model would be to allow for other sources of noise. For instance, the survival of inner hair cells in some subjects could result in some residual synapse-driven spontaneous activity in the AN. This would affect the amount of noise present in the total AN response. Other sources of noise may also be present in more central sections of the auditory pathways. The effects of both of these potential noise sources can be included in our perceptual model if their behavior is known.

By changing parameters of the model to reduce the amount of stochastic activity we may also account for such data which lie somewhere between the deterministic model and the stochastic model predictions. For instance, particularly focused current fields or extremely low neural survival may cause higher probabilities of firing at stimulus intensities within the behavioral operating range. Because neural responses at high discharge probabilities exhibit relatively little variability, stochastic and deterministic model predictions are similar under such conditions.

The physiological data on which our model is based are from acutely implanted animals. This model does not take into account the effects which etiology, prolonged deafness and implantation have on the response of AN fibers to electrical stimulation [31] [37]. An extension to these studies could be to model the effects of various etiologies on single-fiber I/O functions and current spread.

Only responses to stimulation from a single electrode have been investigated in these studies. In order to model responses to stimulation from multiple electrodes, even at moderate pulse rates, refractory effects should be incorporated [1][2] when the electrodes are stimulating overlapping populations of fibers. Also, loudness summation effects may need to be considered when the neural populations excited do not overlap [17][29][33][40].

In these studies we have also limited our investigation to low pulse-rate stimuli. With the pulse-train model developed in [1] and [2] and shown in Figure 7, we may now have an appropriate tool for extending this investigation to the prediction of perceptual data for moderate stimulation rates (200–1,000 pps). However, to develop the model for high pulse rate (> 1,000 pps) stimulation, neurophysiological data must be collected for a range of discharge probabilities (possibly as low as 0.01 or lower) at such high pulse rates. Physiological data

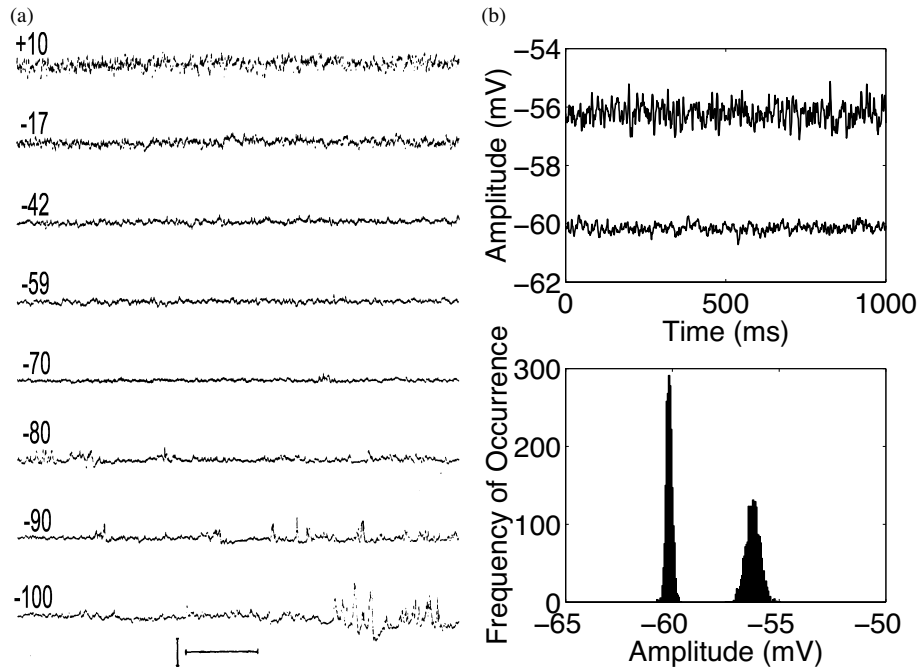

Figure 10 (a) Membrane-potential traces at different levels of membrane potential (given in mV above each trace). Horizontal scale: 1 s; vertical scale: 5 mV. (Reprinted with permission from Fig. 19 of [35] © 1968 IEEE). (b) Model predictions of membrane potential fluctuations (top pane) and their distributions (bottom pane): at resting potential (-60 mV) and at a sustained depolarized potential.

and modeling results [8][19][28] reveal inter-pulse interactions occurring at high pulse rates which can significantly increase or decrease the level of stochastic activity in a fiber.

To further investigate such nonlinearities we are now developing a more computationally efficient stochastic Hodgkin–Huxley type model than those such as Rubinstein’s [27][28]. This is achieved by applying Chua’s [5] reformulation of the Hodgkin–Huxley model to Fox and Lu’s [10] stochastic version of the model. Chua’s reformulation permits efficient simulation of complex biological neurons using a standard circuit analysis program such as SPICE [23][32]. Initial simulation results show that such a model can accurately and efficiently predict a number of properties of the random fluctuations in the membrane potential as characterized by Verveen et al. [35]. Plotted in Figure 10 are membrane-potential traces from [35] showing fluctuations in nerve-fiber transmembrane potentials at the nodes of Ranvier and model predictions of these fluctuations. Both Verveen’s recordings and the model predictions exhibit a Gaussian amplitude distribution and an increase in membrane noise variance with depolarization. The model also predicts the $1/f$ frequency spectrum observed by Verveen et al., which tends towards a white (flat) spectrum at higher frequencies.

However, there is some preliminary evidence that the Fox and Lu approximation may become inaccurate when the model neuron is spiking [Jay Rubinstein, pers. comm.]. One possibility is that the approximation deals incorrectly with the noise distribution when the membrane is hyperpolarized or depolarized, which Verveen and Derksen observed to be highly non-Gaussian [36]. If this can be corrected, then with Chua’s reformulation we will

be able to investigate simply and efficiently how stochastic versions of both single-node models and anatomically correct multi-node models [7][11] predict physiological data for pulsatile cochlear implant stimulation.

5. Summary and Conclusions

A number of aspects of cochlear implant physiology and perception are better predicted by a stochastic model than by the equivalent deterministic model. These results show that loudness perception in implant subjects is highly dependent on the statistics of AN response, not just on some form of absolute threshold. This may imply that loudness perception of acoustic stimuli in normal hearing and hearing-impaired subjects is also dependent on the statistics of AN response, not just on absolute thresholds. High-rate electrical stimulation may produce significant inter-pulse interactions related to changes in levels of membrane noise, which cannot be predicted by deterministic models.

Acknowledgments

The authors would like to thank Scott Dynes and Eric Javel for their contribution of physiological data, and Chris van den Honert and Charlie Finley for their assistance given to Mark White in initial investigations of stochastic activity in the auditory nerve. This work was funded by the Human Communication Research Centre, The University of Melbourne, the Bionic Ear Institute, and the CRC for Cochlear Implants, Speech and Hearing Research.

References

- [1] Bruce, I. C., Irlicht, L. S., White, M. W., O'Leary, S. J. and Clark, G. M. "Renewal-process approximation of a stochastic threshold model for electrical neural stimulation." *J. Comput. Neurosci.*, 9(2): 119–132, 2000
- [2] Bruce, I. C., Irlicht, L. S., White, M. W., O'Leary, S. J., Dynes, S., Javel, E. and Clark, G. M. "A stochastic model of the electrically stimulated auditory nerve: Pulse-train response." *IEEE Trans. Biomed. Eng.*, 46(6): 630–637, 1999.
- [3] Bruce, I. C., White, M. W., Irlicht, L. S., O'Leary, S. J. and Clark, G. M. "The effects of stochastic neural activity in a model predicting intensity perception with cochlear implants: Low-rate stimulation." *IEEE Trans. Biomed. Eng.*, 46(12): 1393–1404, 1999.
- [4] Bruce, I. C., White, M. W., Irlicht, L. S., O'Leary, S. J., Dynes, S., Javel, E. and Clark, G. M. "A stochastic model of the electrically stimulated auditory nerve: Single-pulse response." *IEEE Trans. Biomed. Eng.*, 46(6): 617–629, 1999.
- [5] Chua, L. O. "Device modeling via basic nonlinear circuit elements." *IEEE Trans. Circuits Syst., CAS-* 27(11): 1014–1044, 1980.
- [6] Cohen, L. T., Saunders, E., Busby, P. A. and Clark, G. M. "Place information in cochlear implants: An integrated approach employing psychophysics and modeling." In *Program and Abstracts of 1997 Conference on Implantable Auditory Prostheses*, Asilomar Conference Center, Pacific Grove, California, 1997.
- [7] Colombo, J. and Parkins, C. W. "A model of electrical excitation of the mammalian auditory-nerve neuron." *Hear. Res.*, 31: 287–312, 1987.
- [8] Dynes, S. *Discharge Characteristics of Auditory Nerve Fibers for Pulsatile Electrical Stimuli*. Ph.D. thesis. Massachusetts Institute of Technology, 1996.
- [9] Ferguson, W. D., Smith, D. W., Finley, C. C., Pflugst, B. E. and Collins, L. M. "Prediction of the variance in behavioral thresholds using a stochastic model of electrical stimulation." *ARO Midwinter Meeting Abstracts*, 1998 (see <http://www.ee.duke.edu/~wdf/ARO/index.htm>).
- [10] Fox, R. F. and Lu, Y.-N. "Emergent collective behavior in large numbers of globally coupled independently stochastic ion channels." *Phys. Rev. E*, 49(4): 3421–3431, 1994.
- [11] Frijns, J. H. M. *Cochlear Implants — A Modelling Approach*. Ph.D. thesis. Leiden University, The Netherlands, 1995.
- [12] Hill, A. V. "Excitation and accommodation in nerve." *Proc. R. Soc. B*, 119: 305–355, 1936.

- [13] Hochmair-Desoyer, I. J., Hochmair, E. S., Motz, H. and Rattay, F. "A model for the electrostimulation of the nervus acusticus." *Neurosci.*, 13(2): 553–562, 1984.
- [14] Irlight, L. S. and Clark, G. M. "Control strategies for neurons modeled by self-exciting point processes." *J. Acoust. Soc. Am.*, 100: 3237–3247, 1996.
- [15] Javel, E., Tong, Y. C., Shepherd, R. K. and Clark, G. M. "Responses of cat auditory nerve fibers to biphasic electrical current pulses." *Ann. Otol. Rhinol. Laryngol.*, 96 (Suppl. 128): 26–30, 1987.
- [16] Kistler, W. M., Gerstner, W. and van Hemmen, J. L. "Reduction of the Hodgkin–Huxley equations to a single-variable threshold model." *Neural Comput.*, 9(5): 1015–1045, 1997.
- [17] McKay, C. M., McDermott, H. J. and Clark, G. M. "Loudness summation for two channels of stimulation in cochlear implants: Effects of spatial and temporal separation." *Ann. Otol. Rhinol. Laryngol.*, 104 (Suppl. 166): 230–233, 1995.
- [18] Merzenich, M. M. and White, M. W. "Cochlear implants: The interface problem." In *Functional Electrical Stimulation: Applications in Neural Prostheses*, Volume. 3, F. T. Hambrecht and J. B. Reswick (eds.), New York: Marcel Dekker, pp. 321–340, 1977.
- [19] Miller, C. A., Abbas, P. J., Robinson, B. K., Rubinstein, J. T. and Matsuoka, A. J. "Electrically evoked single-fiber action potentials from cat: Responses to monopolar, monophasic stimulation." *Hearing Res.*, 130: 197–218, 1999.
- [20] O’Leary, S. J., Black, R. C. and Clark, G. M. "Current distributions in the cat cochlea." *Hearing Res.*, 18: 273–281, 1985.
- [21] O’Leary, S. J., Clark, G. M. and Tong, Y. C. "Model of discharge rate from auditory nerve fibers responding to electrical stimulation of the cochlea: Identification of cues for current and time-interval coding." *Ann. Otol. Rhinol. Laryngol.*, 104 (Suppl. 166): 121–123, 1995.
- [22] Parkins, C. W. "Temporal response patterns of auditory nerve fibers to electrical stimulation in deafened squirrel monkeys." *Hearing Res.*, 41: 137–168, 1989.
- [23] Parodi, M. and Storaice, M. "On a circuit representation of the Hodgkin and Huxley nerve axon membrane equations." *Int. J. Circuit Theory Appl.*, 25: 115–124, 1997.
- [24] Pfungst, B. E. "Comparisons of psychophysical and neurophysiological studies of cochlear implants." *Hear. Res.*, 34: 243–252, 1988.
- [25] Pfungst, B. E. "Psychophysical constraints on biophysical/neural models of threshold." In *Cochlear Implants – Models of the Electrically Stimulated Ear*, J. M. Miller and F. A. Spelman (eds.), New York: Springer-Verlag, pp. 161–185, 1990.
- [26] Pfungst, B. E., Haan, D. R. D. and Holloway, L. A. "Stimulus features affecting psychophysical detection thresholds for electrical stimulation of the cochlea. I: Phase duration and stimulus duration." *J. Acoust. Soc. Am.*, 90: 1857–1866, 1991.
- [27] Rubinstein, J. T. "Threshold fluctuations in an N sodium channel model of the node of Ranvier." *Biophysical Journal*, 68: 779–785, 1995.
- [28] Rubinstein, J. T., Wilson, B. S., Finley, C. C. and Abbas, P. J. "Pseudo spontaneous activity: Stochastic independence of auditory nerve fibers with electrical stimulation." *Hearing Res.*, 127(1–2): 108–118, 1999.
- [29] Shannon, R. V. "Multichannel electrical stimulation of the auditory nerve in man. II. Channel interaction." *Hearing Res.*, 12: 1–16, 1983.
- [30] Shannon, R. V. "A model of threshold for pulsatile electrical stimulation of cochlear implants." *Hearing Res.*, 40: 197–204, 1989.
- [31] Shepherd, R. K. and Javel, E. "Electrical stimulation of the auditory nerve: I. Correlation of physiological responses with cochlear status." *Hear. Res.*, 108: 112–144, 1997.
- [32] Storaice, M., Bove, M., Grattarola, M. and Parodi, M. "Simulations of the behavior of synaptically driven neurons via time-invariant circuit models." *IEEE Trans. Biomed. Eng.*, 44(12): 1282–1287, 1997.
- [33] Tong, Y. C. and Clark, G. M. "Loudness summation, masking, and temporal interaction for sensations produced by electric stimulation of two sites in the human cochlea." *J. Acoust. Soc. Am.*, 79: 1958–1966, 1986.
- [34] van den Honert, C. and Stypulkowski, P. H. "Single fiber mapping of spatial excitation patterns in the electrically stimulated auditory nerve." *Hearing Res.*, 29: 195–206, 1987.
- [35] Verveen, A. A. and Derksen, H. E. "Fluctuation phenomena in nerve membrane." *Proc. IEEE*, 56(6): 906–916, 1968.

- [36] Verveen, A. A. and Derksen, H. E. "Amplitude distribution of axon membrane noise voltage." *Acta Physiol. Pharmacol. Neerl.*, 15: 353–379, 1969.
- [37] Viemeister, N. F., Javel, E. and Ganesan, G. K. "Auditory nerve correlates of intensity discrimination for electrical stimuli." *ARO Midwinter Meeting Abstracts*, 1997.
- [38] White, M. W. *Design Considerations of a Prosthesis for the Profoundly Deaf*, Ph.D. thesis, University of California, Berkeley, 1978.
- [39] White, M. W., Finley, C. C. and Wilson, B. S. "Electrical stimulation model of the auditory nerve: Stochastic response characteristics." *Proc. Ninth Ann. Conf. IEEE Eng. Med. Biol. Soc.*, Boston, pp. 1906–1907, 1987.
- [40] White, M. W., Merzenich, M. M. and Gardi, J. N. "Multi-channel cochlear implants: Channel interactions and processor design." *Arch. Otolaryngol.*, 110: 493–501, 1984.